

HALF-WAVE RECTIFIER

Mercury vapour half-wave rectifier for use
in high voltage rectifier circuits.

RG4-1250

This data should be read in conjunction with GENERAL OPERATIONAL
RECOMMENDATIONS — GAS-FILLED RECTIFIERS, preceding this
section of the handbook.

LIMITING VALUES (absolute ratings, not design centre)

It is important that these limits are never exceeded and such variations as
mains fluctuations, component tolerances and switching surges must be
taken into consideration in arriving at actual valve operating conditions.

*Max. peak inverse anode voltage	20	10	kV
*Condensed mercury temperature limits	20 to 40	20 to 55	°C
Max. cathode current			
Peak		5.0	A
Average (max. averaging time 15s)		1.25	A
Surge (fault protection max. duration 0.1s)		25	A
Filament voltage limits		3.9 to 4.1	V
Max. operating frequency		150	c/s

*Max. condensed mercury temperature rating for intermediate anode
voltages may be determined by linear interpolation.

CHARACTERISTICS

Electrical

Filament voltage	4.0	V
Average filament current at 4.0V	11	A
Anode voltage drop	12	V

Mechanical

Equilibrium condensed mercury temperature rise above ambient		
At full load (approx.)	16	°C
At no load (approx.)	14	°C
Mounting position	Vertical, base down	
Max. net weight	{ 258	g
	{ 9.0	oz



RG4-1250

HALF-WAVE RECTIFIER

Mercury vapour half-wave rectifier for use
in high voltage rectifier circuits.

FULL LOAD OPERATING CONDITIONS (for peak inverse anode voltage of 20 kV and peak cathode current of 5.0A)

Circuit	No. of valves	Full load d.c. output		Applied a.c. volts (kV _{r.m.s.})	Initial filter elements	
		(kV)	(A)		Lmin. (H)	Cmax. (μF)
Single phase full-wave	2	6.3	2.5	7.0 (per valve)	4.0	5.0
Single phase bridge	4	12.6	2.5	14 (total)	8.0	2.5
Three phase half-wave	3	8.2* (9.5)	3.75	7.0* (8.1) (per phase)	3.0	2.0
Three phase full-wave	6	19.1	3.75	8.1 (per phase)	4.0	1.0

*These figures take into account the increase in peak inverse voltage which occurs if the power supply is lightly loaded. For operation with a constant load the voltages may be increased to the value shown in brackets.

HEATING UP TIME

The preferred minimum value of the total valve heating up time can be obtained from the heating and cooling curve on page 4. This shows how the condensed mercury temperature rises above the ambient temperature from the instant of switching on the filament supply.

Under normal conditions, however, cathode current may be drawn when the condensed mercury temperature is approximately within 7°C of the minimum quoted value. (See page 5 and also appropriate section of 'General operational recommendations—gas-filled rectifiers'.)

Minimum cathode heating time 1 min.

HALF-WAVE RECTIFIER

RG4-1250

*Mercury vapour half-wave rectifier for use
in high voltage rectifier circuits.*

3269

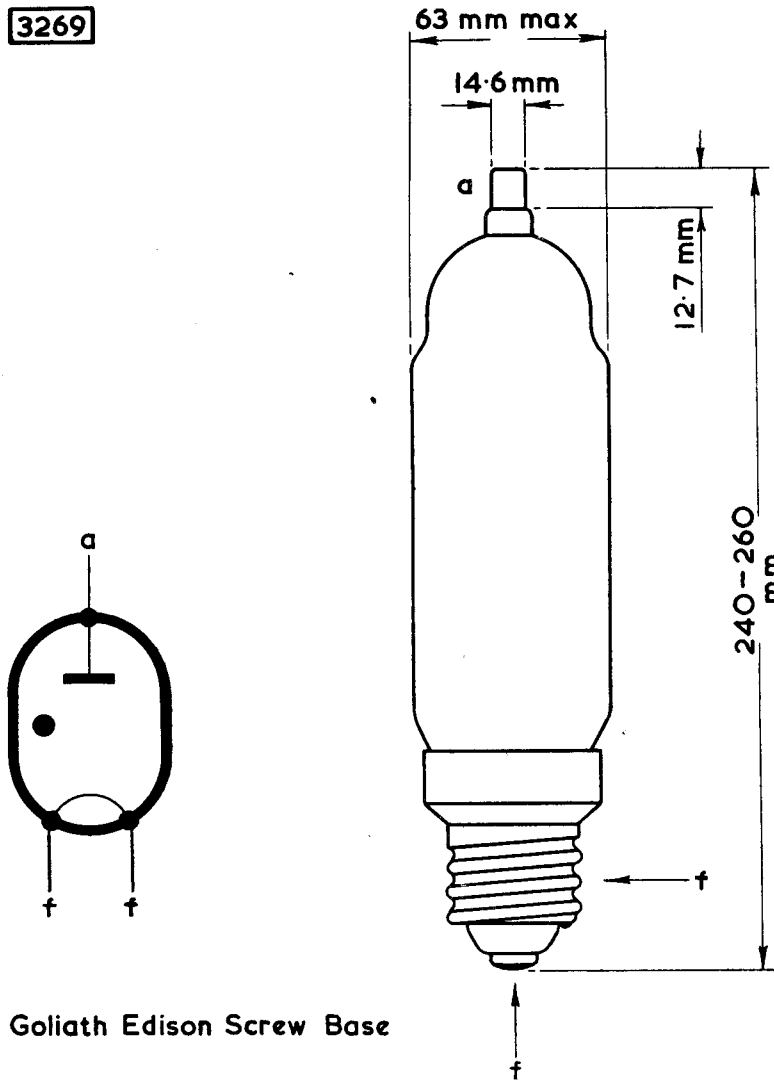

RG4-1250

HALF-WAVE RECTIFIER

Mercury vapour half-wave rectifier for use
in high voltage rectifier circuits.

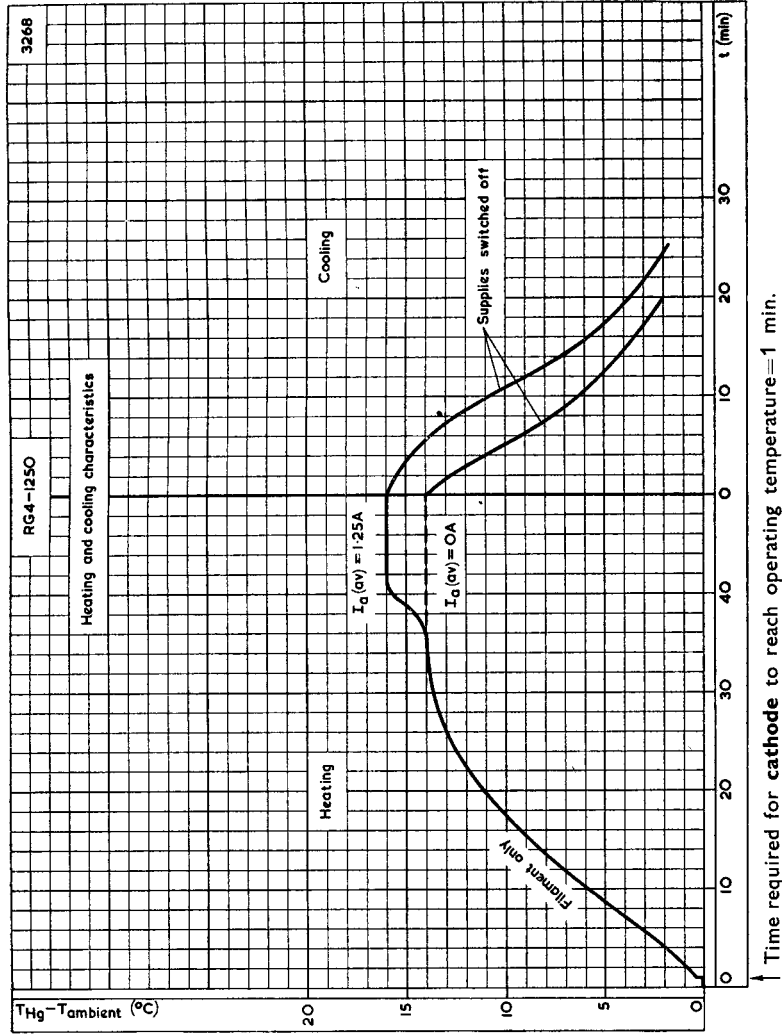

HEATING AND COOLING CHARACTERISTIC. EXCESS TEMPERATURE OVER
AMBIENT PLOTTED AGAINST TIME

HALF-WAVE RECTIFIER

RG4-1250

Mercury vapour half-wave rectifier for use
in high voltage rectifier circuits.

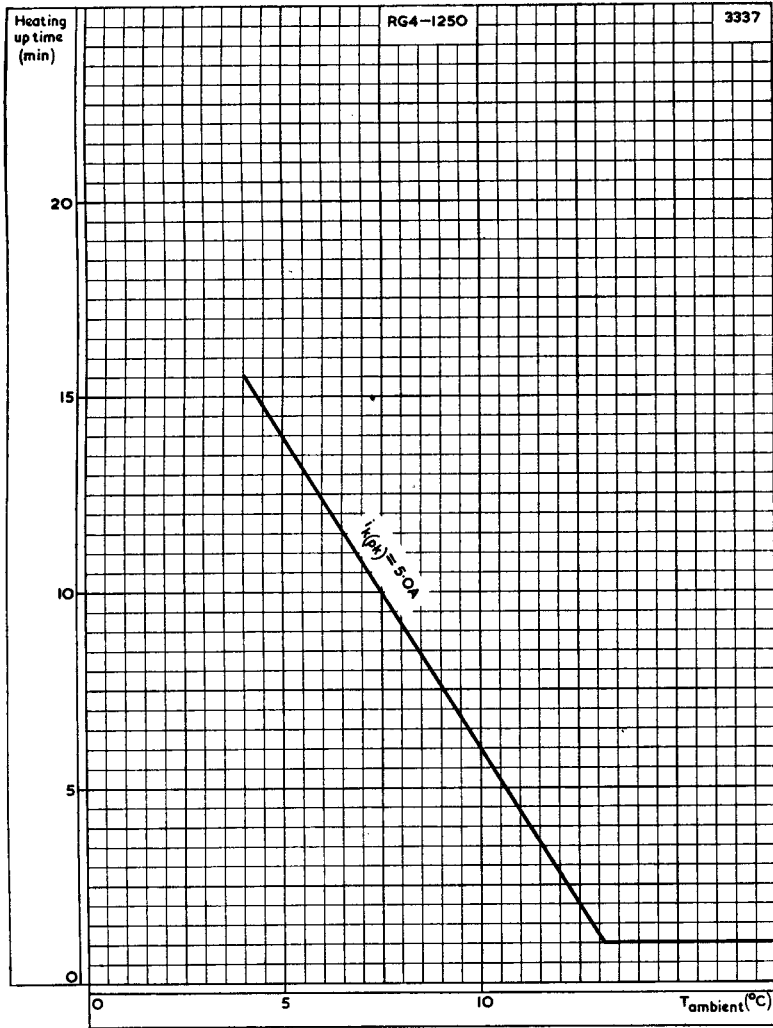

TOTAL HEATING UP TIME PLOTTED AGAINST AMBIENT TEMPERATURE

