

Specification MOS(A)/CV2325	<u>SECURITY</u>	
Issue 1 Dated 26. 5. 54.	<u>Specification</u>	<u>Valve</u>
To be read in conjunction with K1001.	UNCLASSIFIED	UNCLASSIFIED

TYPE OF VALVE - Decade Selector Tube				<u>MARKING</u>	
CATHODES - Cold				See K1001/4	
ENVELOPE - Glass-Unmetallised				<u>BASE</u>	
PROTOTYPE - GS10C				B12A with bottom cap	
<u>RATING</u>				<u>CONNECTIONS</u>	
			Note	Pin	Electrode
Max. Counting Speed	(digits/sec.)	4000	A, B	1	Cathode 0
Max. Striking Voltage	(V)	400	C	2	" 9
Min. Anode Current	(μ A)	250		3	" 8
Max. Anode Current	(μ A)	550		4	" 7
Nominal Maintaining Voltage at 300 μ A	(V)	192		5	" 6
Maximum P.D. between Guides and Cathodes	(V)	140		6	" 5
Signal Pulse Amplitude	(V)	145	A	7	" 4
Min. Pulse Duration	(μ S)	50	A	8	" 3
Min. Quiescent Period	(μ S)	200	A	9	" 2
Guide Bias	(V)	36	A	10	" 1
Sine-wave Amplitude				11	Second Guides
Second Guide	(V RMS)	55	B	12	First Guides
Phase Advance, First Guide	(degrees)	45	B	Bottom Cap	Anode
Guide Bias	(V)	0	B	<u>DIMENSIONS</u>	
Max. Cathode Loads	(ohms)	270000		See K1001/A1/D1 also Drawing on Page 3	
				Dimensions (mm)	Min. Max.
				A	83.5 90.5
				B	30.9 33.1
				C	- 35.0
				L	63.5 70.5
				Bottom Cap Length	5.3 8.1
				Dia.	6.2 6.5
				<u>MOUNTING POSITION</u>	
				Any	

NOTES

- A. When operating in the circuit shown in Fig. 1 on Page 3.
- B. When operating in the test circuit shown in Fig. 2 on Page 3.
- C. Measured with normal room illumination.

TESTS

To be performed in addition to those applicable in K1001.

	Test Conditions	Test	Limits		No. Tested	Note
			Min.	Max.		
a	400V shall be applied through 560K to anode. Each cathode and each group of guides shall be connected to earth in turn. Tube shall be tested in normal room daylight.	Time to Strike (secs) Test shall be performed 12 times.	-	10	100%	
b	Ia shall be adjusted to 300 μ A for each cathode and guide in turn.	Maintaining Voltage (V) Test shall be performed 30 times.	186	198	100%	
c	The tube shall be operated in the test circuit shown in Fig. 2 on Page 3. Sine waves shall be applied to the tube to produce a clockwise rotation of glow at 4 kc/s.	Tube must divide accurately in the ratio 10:1.	-	-	100%	
d	As for Test (c), but with anti-clockwise rotation of glow at 4 kc/s.	As for Test (c)	-	-	100%	
e	Each cathode in turn, shall be connected to earth and 440V applied to anode through 560K. First and second guides shall be at +45V.	Glow must appear only at the tip of the appropriate cathode. Tests shall be performed 10 times.	-	-	100%	
f	50V shall be applied between each electrode and parallel connection of the remainder in turn.	Insulation (megohms)	100	-	100%	

FIGURE 1.

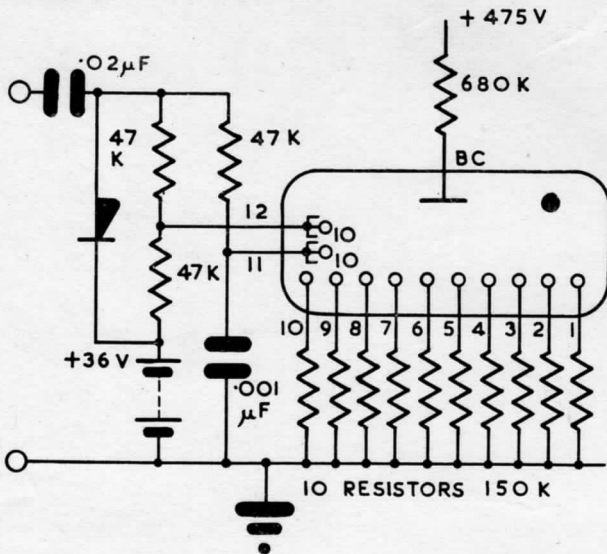
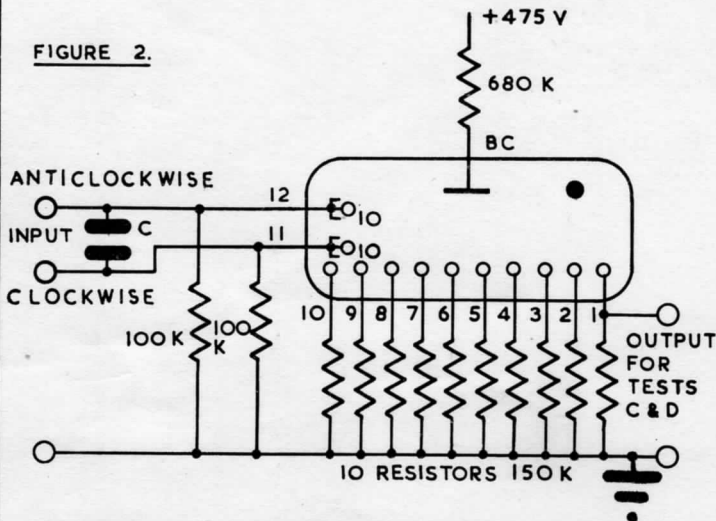
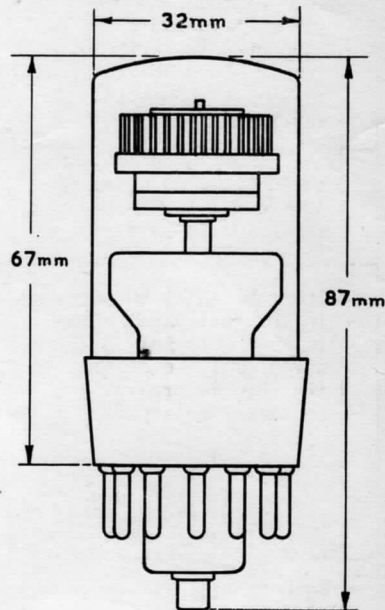

FIGURE 2.



THE VALUE OF C IS CHOSEN TO PRODUCE A 45° PHASE ADVANCE AT 4 kc/s C = 680 pF.

FIGURE 3.



CATHODE No.1 IS ALIGNED WITH PIN No.11 TO WITHIN ± 12°.