

A Two-Way Stereophonic Amplifier

B. B. BAUER,^o J. HOLLYWOOD,^o and G. MAERKLE^o

With this ingenious circuit, stereophonic phono systems may be reduced in number of tubes required and consequent cost while maintaining low distortion and simple amplifier design for medium-power installations.

NOT THE LEAST of the problems of stereophonic reproduction is that of space and cost. The necessity of providing two separate reproducing channels doubles everything with the exception of the pickup stylus. It is evident that if stereophony is to be enjoyed by a wide segment of population, new engineering approaches must be found for minimizing the bulk and cost of stereophonic equipment without sacrificing quality. The amplifier described in this article helps to solve this problem.

The new amplifier is called a "two-way amplifier" because it uses a single push-pull stage to amplify two independent signals. Its total power output is equivalent to that of a single push-pull amplifier using the same tube complement. The separation between the two channels on the average is better than 25 db. The cost is only a little more than that of a single push-pull amplifier and considerably less than that of two separate push-pull amplifiers of similar total performance.

To understand the principles upon which the new amplifier is based, reference is made to Fig. 1, which illustrates

^o CBS Laboratories, 227 High Ridge Road, Stamford, Connecticut.

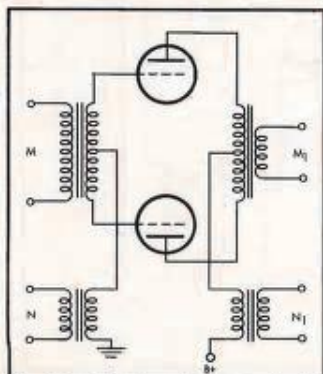

Fig. 1. Amplification of two signals with a push-pull stage.

AUDIO • OCTOBER, 1958

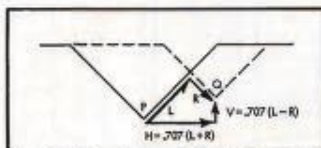

Fig. 2. Equivalence of 45/45 L and R modulation and H and V Sum-and-Difference modulation.

a push-pull output stage operating in class A or AB. This stage differs from a conventional transformer-coupled push-pull stage in having two instead of one input and output transformers. A signal applied to the winding *M* only will drive the two grids in opposition, so that the stage will perform in a conventional push-pull fashion, i.e. an output signal will appear at the winding *M₁*, and since the incremental plate currents will be oppositely directed there will be no output at *N₁*. A signal applied to the winding *N* only will drive both grids equally and the incremental plate current will be in the same direction resulting in parallel operation, i.e. there will be output at *N₁*, but not at *M₁*. Such a push-pull stage will amplify two independent signals with little interaction, and it could conceivably be used to am-

plify the left (*L*) and the right (*R*) stereophonic signals independently of each other. Its operation, however, would not be entirely satisfactory. One of the obvious faults, for example, is that the two channels are not identical. The push-pull channel will have a greater power handling capacity than the parallel channel for given frequency response and distortion, and in stereophonic work it is best to provide channels of equal capacity for both signals.

Improved Circuit Arrangement

An improved circuit can be provided by considering an additional principle. In Fig. 2 is shown a stereophonic groove in cross-sectional view. Let us assume that in the process of modulation the apex of the groove is driven from the point *P* to the point *Q*. This comes about because of two stereophonic 45/45-deg. signals *L* and *R*. We notice at this point that precisely the same result would have been accomplished by a horizontal modulation $H = .707(L + R)$, and a vertical modulation $V = .707(L - R)$. Therefore, except for the factor .707, a 45/45 modulation is equal to a horizontal-vertical modulation in which the sum signal $S = L + R$ is recorded horizontally and

Fig. 3. Reproduction of Left and Right channels played as S and D signals with a Horizontal-Vertical pickup.

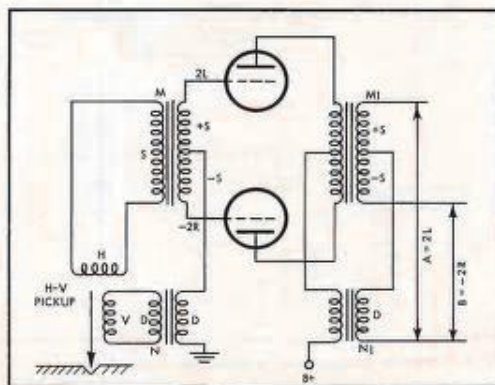

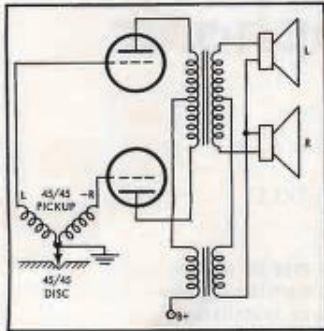

Fig. 4. The use of the Two-Way amplifier with a 45/45 pickup.

the difference signal $D=L-R$ is recorded vertically. This is an important identity which should be kept in mind: The two systems are really one and the same but are merely expressed by a different set of equations. It has been observed that the sum signal S is apt to carry the bulk of the power while the difference signal D principally conveys the stereophonic information.

Let us now consider one way of combining these principles to achieve the reproduction of a 45/45 record with the single push-pull stage. The record may be reproduced with a horizontal-vertical pickup connected as shown in Fig. 3.

The horizontal section reproduces the sum signal $S=L+R$ and its output is applied to the input winding M which will actuate the stage in accordance with its maximum power handling capability. The vertical section reproduces the difference signal $D=L-R$ and its output is connected to the winding N . The winding M , is now center-tapped and provided with sufficient turns to generate two signals $+S$ and $-S$. One side of N , is connected to this center tap. The voltages between the other side of N , and the two free ends of M , now may be calculated as follows:

$$A = D + S = (L - R) + (L + R) = 2L$$

$$B = D - S = (L - R) - (L + R) = -2R$$

Thus we see that a horizontal-vertical pickup combined with the special push-pull stage and matrixing output transformers will produce two independent L and R signals from a 45/45 disc. These two signals may be applied to the stereophonic loudspeakers in the usual manner; noting however that the phase of one of them is reversed, but this can be readily corrected by reversing one pair of leads. The performance of this unit will be indistinguishable from that of two independent amplifiers and loudspeakers driven with a 45/45 pickup.

Use with 45/45 Pickup

The final question now can be answered: How to use this stage with a

45/45 pickup? Consider the potentials at the grids of the tubes. Referring again to Fig. 3, the upper grid has a potential $(L-R) + (L+R) = 2L$ and the lower grid has the potential $(L-R) - (L+R) = -2R$. Therefore, the potentials at the two grids are equal and opposite to those supplied by a conventional 45/45 pickup. Some stereophonic pickups have four terminals and they will be directly usable with the two-way amplifier by suitable connection. Other pickups are purposely provided with terminals of opposite polarity. Such an arrangement is shown in Fig. 4.

It should be noted that by reversing the phase of one of the stereophonic signals, the single stage will continue to handle a virtual sum signal in push-pull and a virtual difference signal in parallel, and this will utilize its capabilities most effectively. One of the loudspeakers is also reversed in phase as previously mentioned to preserve the proper phasing of the sound from both channels.

Advantages

The two-way amplifier has several advantages over two equivalent single-ended amplifiers. A good single-ended stage is difficult to design because of the saturation of the output transformer iron. In the two-way amplifier the push-pull transformer is not subject to saturation. This transformer carries the sum

(Continued on page 92)

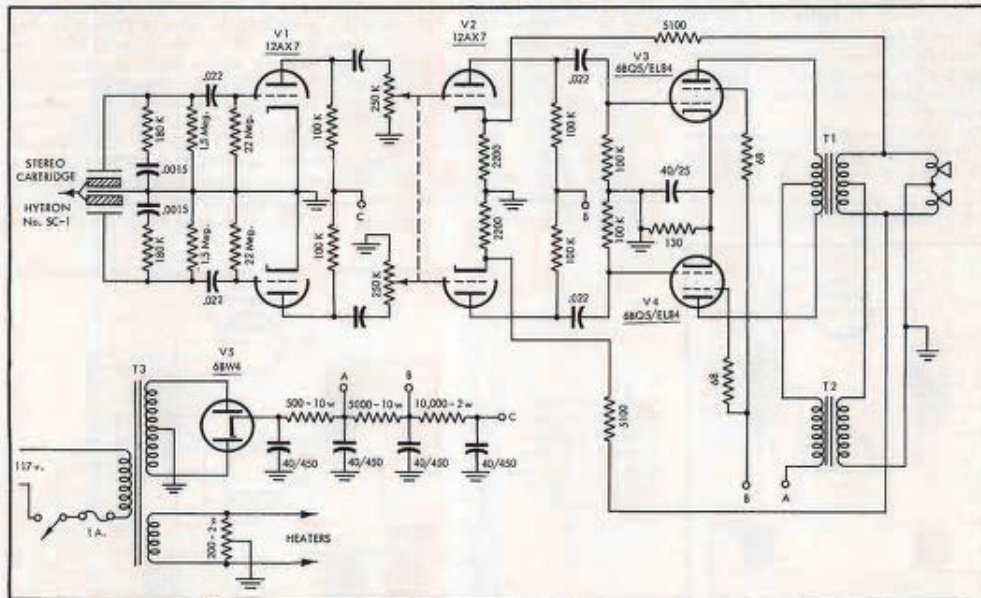

Fig. 5. Complete schematic of a practical amplifier using the Two-Way principle to provide a total of 10 watts of power at less than 1 per cent harmonic distortion.

McIntosh goes STEREO at LEONARD RADIO!



Stereo Audio Compensator C-8S

McIntosh C-8S adds Stereo and improves monaural listening! Here is a control unit that sacrifices absolutely nothing when you add Stereo. Balance of tonal quality from unmatched equipment such as amplifiers and speakers can be achieved only with the C-8S because of the complete flexibility of equalization and tone compensation. The C-8S does NOT duplicate any other equipment, it can be used with any other preamplifier! With the C-8S you add stereo. C-8S, without cabinet—\$99.00; C-8SB, blonde cabinet—\$109.00; C-8SM, Mahog. cabinet—\$109.00. Unique control features: Stereo Balance Control, Stereo Mode Selector, Ganged Stereo MASTER volume control, plus—all the other versatile functions of the superb McIntosh C-8 compensator.



30 Watt Amplifier MC-30

30 watts power (60 watts peak). Harmonic distortion: (20-20,000 cycles) 1.3% at 30 watts, 0.1% at 15 watt! Inter-modulation distortion: Guaranteed below 1/2% at full 60 watts peak output. Hum level inaudible: 90 db below rated output. Two inputs: 0.5 volts 500 K with gain control and 2.5 volts. Damping factor: 12 or better for 4, 8 and 16 ohm output. The outstanding performance of the MC-30 assures new listening enjoyment without fatigue. \$145.50.

Mail & Phone
Orders Filled
25% Deposit,
Balance C.O.D.

LEONARD RADIO, INC.
69 Corlandt St., New York 7, N.Y. Corlandt 7-0315

Circle 92A

British Precision Workmanship
Guarantees Finest Hi-Fi Reproduction

PARTRIDGE Output TRANSFORMERS

*The Heart
of Your
Hi-Fi*



The secondary is brought out as four separate sections which may be connected in series or parallel to match speaker impedances of 0.95, 3.8, 8.5 and 15 ohms by this arrangement.

- Each half primary is brought out to terminals at separate windings and is tapped for ultra linear performance.
- Latest grain orientated cores. Fully interleaved.

\$200 Series — for use in 20 or 35 watt amplifiers with distortion less than 1%.

Available in 4 models

Model #

Plate to Plate Load

Tapped At

P5201

9 — 12K ohms

43%

P5202

7 — 9K ohms

43%

P5203

3 — 7K ohms

42%

P5204

3 — 5K ohms

20%

\$2500
NET

\$300 Series — for use in 35 to 50 watt amplifiers with distortion less than 1%.

Available in 4 models

Model #

Plate to Plate Load

Tapped At

P5351

9 — 12K ohms

43%

P5352

7 — 9K ohms

42%

P5353

5 — 7K ohms

41%

P5354

3 — 5K ohms

20%

\$3000
NET

Write for Free Brochure and Name of Nearest Dealer



PARTRIDGE TRANSFORMERS, LTD.

Sole U. S. Rep. M. SWEDGAL 258 Broadway, New York 7, N. Y.

Circle 92B

92

The basic principles underlying these and other decisions of the courts for more than a century of litigation, were summarized recently by the federal court of appeals, "The law is fairly clear. Absent a contrary understanding the mere existence of an employer-employee relationship does not entitle the employer to ownership of an invention of the employee. This is true even though the employee uses the time and facilities of the employer, although the latter, in that event, may have 'shop rights' therein, that is, the right to a free, non-exclusive personal license to use the invention in his business.

"On the other hand, if the employee is hired to invent or is assigned the duty of devoting his efforts to a particular problem, the resulting invention belongs to the employer."⁹

⁹Marshall v. Colgate-Palmolive-Peet Co., 175 Fed. 2d 215, June 2, 1949.

TWO-WAY AMPLIFIER

(from page 20)

signal which determines the main quality and power of both stereophonic channels. Distortion is kept low because of the push-pull action. The parallel transformer handles the difference signal, and here saturation is unimportant, because the difference signal may be attenuated at low frequencies without appreciable loss in stereophonic localization. A loss of separation will occur at the extreme low frequency which is actually advantageous in that it diminishes the problems of rumble and mechanical feed back. Furthermore, the L and R channels are now identical and the symmetry of the system is preserved.

A practical circuit for the amplifier is shown in Fig. 5. A ceramic pickup may be used, with suitable connection to produce the (L) and (-R) signals. The two inverse feedback loops are provided from the output stage to the cathodes of the input stage, with the usual benefit of the inverse feedback, plus an added improvement in channel separation. The power handling capacity of this amplifier is 10 watts average or 20 watts peak at 0.8 per cent total harmonic distortion for both channels and about half that amount for each of the two channels used singly.

The authors appreciate the many valuable contributions made by Mr. William S. Bachman in applying this circuit to the Columbia line of stereophonic phonographs.

The two-way amplifier will be available in the near future as a kit from the Heath Company.

AUDIO • OCTOBER, 1958