

MINISTRY OF SUPPLY - D.L.R.D.(T)

Specification MOS/CV4515 Issue 1 dated 17.11.58 To be read in conjunction with K.1001	<u>SECURITY</u>	
	<u>Specification</u>	<u>Valve</u>
	UNCLASSIFIED	UNCLASSIFIED

→ Indicates a change

TYPE OF VALVE - Rugged Tunable Klystron Oscillator with Integral Cavity and Waveguide Output.		<u>MARKING</u>			
CATHODE	- Indirectly - heated	See K.1001/4			
ENVELOPE	- Shielded Metal Glass	Additional Marking:-			
PROTOTYPE	- VX 9081	Serial No.			
<u>RATINGS</u> (Note A) (All limiting values are absolute)		Note	<u>BASE</u> See drawing on Page 8		
Heater Voltage (V)	6.3	B	<u>CONNECTIONS</u> See drawing on Page 8		
Heater Current (A)	0.56		C	<u>DIMENSIONS</u> See drawing on Page 8	
Mechanical Tuning Frequency Range (Mc/s)	9,000 to 10,000			D	<u>MOUNTING POSITION</u> Any
Min. R.F. Power Output (mW)	30	E			
Max. Resonator Voltage (V)	400				
Max. Resonator Dissipation (W)	20				
Reflector Voltage Range (Vres. = 350V) (V)	-250 to -400				
Max. Mechanical Resetting Error (Mc/s)	3				
Min. Electronic Tuning Range (Mc/s)	± 10				
Min. Electronic Tuning Gradient at Mode Optimum (Mc/s/V)	0.5				
Max. Total Impedance in Reflector to Cathode Circuit (Mohms)	0.5				
Max. Operating Ambient Temperature (°C)	70				
Max. Ambient Storage Temperature Range (°C)	-60/+85				
Max. Body Temperature (°C)	165				
Max. Vibration (10 Minutes duration Max.) (g)	20				
Max. Constant Acceleration (g)	50				
Min. Operating Pressure (mm. Hg)	20				
<u>NOTES</u>					
A. <u>Caution to Electronic Equipment Design Engineers:</u> Special attention should be given to the temperature of valves to be operated in Guided Weapons and Aircraft. Reliability will be seriously impaired if the maximum body temperature is exceeded. The life expectancy may be reduced if conditions other than those specified for life test are imposed on the valve and will be reduced appreciably if absolute maximum ratings are exceeded. Both reliability and performance will be jeopardized if Heater Voltage ratings are exceeded; life and reliability performance are directly related to the degree that regulation of the Heater Voltage is maintained at its rated value. Under no circumstances should the Heater Voltage supply be allowed to deviate more than ± 5% from the rated value, except for quick warm-up applications when it is permissible to apply, initially, a voltage not exceeding 9 volts for a period of time not exceeding 20 seconds.					
B. Clockwise rotation of the Tuner Shaft increases the frequency.					

/C.

NOTES (Contd.)

- C. The Reflector Voltage must always remain negative with respect to the Cathode. If under A.F.C. working there is any possibility of the Reflector Voltage becoming equal to or more positive than the Cathode, a protective diode must be fitted between the Reflector and Cathode.
- D. Measured at a point on the Resonator body diametrically opposite the waveguide output.
- E. The maximum peak acceleration under short term random vibration conditions specified assumes that the vibration frequency components are varying continuously over the band 10 to 500 cycles/sec. in a random manner.

TESTS

CV4515

TO BE PERFORMED IN ADDITION TO THOSE APPLICABLE IN K.1C01

TESTS IN ANY ONE GROUP SHALL BE PERFORMED IN THE SPECIFIED ORDER

TEST CONDITIONS -- UNLESS OTHERWISE SPECIFIED									
		Vh(V) 6.3	Vres.(V) 350	Vref.(V) Adjust for max. R.F. Power	Tamb.(°C) Room Temperature				
K1001	TEST	TEST CONDITIONS	AQL %	INSP. LEVEL	SYMBOL	LIMITS			UNITS
						MIN.	BOGEY	MAX.	
	<u>GROUP A</u>								
AVI/5,6	Visual Inspection	Note: 1 No Voltages applied		100%					
	Inoperatives			100%					
	Insulation (1)	Vref.-res. = 1000V No other Voltages applied		100%		200	-	-	Mohms
	Heater Current	Vh = 6.3 No other voltages applied		100%	Ih	0.52	0.56	0.61	A
	Torque to turn Tuning Shaft (1)	Note: 2		100%	Tq	-	-	15	cm.ins
	<u>R.F. Tests</u>	Note: 3							
	Power Output	Note: 5	} Note 4	100%	Pout	30	-	-	mW
	Electronic Tuning Range (1)	Note: 6		100%		10	-	-	Mc/s
	Reflector Voltage			100%	Vref.	-250	-	-400	V
	Beam Current			100%	I Beam	25	-	40	mA
	Variation of Power Output	Note: 7		100%		-	-	5.0	dB
	Electronic Tuning Gradient at Mode Optimum	Notes: 8, 9		100%		0.5	-	1.0	Mc/s per Volt
	Ratio of Electronic Tuning Gradient at Mode Optimum to that at the ± 10 db points	Notes: 8, 9		100%		$\frac{1}{3}$	-	-	-
	Reflector Voltage Tracking Error	Notes: 10, 11		100%		-	-	± 3	V
	Incremental Mechanical Tuning Gradient	Notes: 11, 12		100%		5.0	-	9.5	Mc/s per turn
	Average Mechanical Tuning Gradient	Notes: 11, 13		100%		6.5	-	8.0	Mc/s per turn
Resetting Error	Notes: 5, 8, 14, 15		100%		-	-	3.0	Mc/s	

K1001	TEST	TEST CONDITIONS	AQL %	INSP. LEVEL	SYMBOL	LIMITS			UNITS
						MIN.	BOGEY	MAX.	
	<u>GROUP A (Contd.)</u> <u>R.F. Tests (Contd.)</u> <u>Pulling</u> Frequency Deviation Power Output Electronic Tuning Range (2) <u>Mechanical Tests</u> Frequency Modulation Under Vibration (1) Frequency Deviation Under Acceleration (1) Power Deviation Under Acceleration (1)	Notes: 8, 16 Notes: 8, 16 Notes: 8, 16 Notes: 5, 15, 17 Notes: 5, 15, 18 Notes: 5, 15, 18		100% 100% 100% 100% 100% 100%	Pout Tq	- 15 ±10 - - -	+ 10 - - 4.0 2.0 1.0	Mc/s mW Mc/s Mc/s Mc/s dB	
	<u>GROUP E</u> Insulation (2)	Vref.-res. = 1000V No other voltages applied T. body = 165°C min. Note: 19		T/A	R	200	-	-	Mohms
	<u>GROUP E</u> Frequency Modulation Under Vibration (2) Frequency Deviation Under Acceleration (2) Power Deviation Under Acceleration (2) Torque to Turn Tuning Shaft (2)	Notes: 5, 15, 20 Notes: 5, 15, 21. Notes: 5, 15, 21. Notes: 19, 22		T/A T/A T/A T/A	 Tq	 -	 -	4.0 2.0 1.0 15	Mc/s Mc/s dB oz.ins.
AV1/5.3	<u>GROUP F</u> <u>Tuner Cycling Life</u> <u>Test Point 200 Cycles</u> <u>Intermittent Life</u> <u>Test Point 200 hours</u> Power Output Beam Current <u>Heater Cycling Life</u> <u>Test End Point</u>	Note: 23 Note: 24 Note: 25 Note: 26 Note: 27		2 Valves per month 2 Valves per month 2 Valves per month	Pout I beam	20 20 2000	- - - -	- - - -	mW mA cycles

K1001	TEST	TEST CONDITIONS	AQL %	INSP. LEVEL	SYMBOL	LIMITS			UNITS
						MIN.	BOGEY	MAX.	
	<u>Group C</u>								
AIX/2.5	<u>Electrical Re-Test</u> <u>after 28 days</u> <u>holding period</u>			100%					
AVI/5.6	Inoperatives								
	Power Output	Notes: 5, 8			Pout	30	-	-	mW
	Beam Current	Note: 8			J Beam	25	-	40	mA
<u>NOTES</u>									
1.	The valve shall be visually inspected for good workmanship. This test may be carried out alternatively in Group G.								
2.	This test, which is to be a measurement of Starting Torque, is to be made:-								
	(a) With all supplies off and all parts of the valve stabilised at an ambient temperature between 10°C and 40°C.								
	(b) With all supplies on and the temperature stabilised at the normal operating temperature with an ambient temperature between 10°C and 40°C.								
3.	The tuning range 9,000 to 10,000 Mc/s. must be continuous and must be covered in one Reflector Mode.								
4.	These tests may be combined and shall be carried out at the following frequencies:-								
	(a) 9,000 Mc/s.								
	(b) At a random point in the band 9,000 to 10,000 Mc/s.								
	(c) 10,000 Mc/s.								
	with the exception of the Beam Current Test which shall be carried out only at a random point in the band 9,000 to 10,000 Mc/s.								
5.	Measured with the valve working into a load of V.S.W.R. not greater than 1.1 to 1.								
6.	The Electronic Tuning Range is to be measured from the mode optimum to the 3 dB points of the Reflector Mode with the Reflector Voltage traversed in both an increasing and a decreasing direction to the extinction points.								
7.	On any individual valve, the ratio of the maximum and minimum values of Power Output over the band 9,000 to 10,000 Mc/s. shall not exceed the limit specified, the measurements being made at Mode Optimum.								
8.	This test to be carried out at a random point in the band 9,000 to 10,000 Mc/s.								
9.	The Electronic Tuning Gradient is defined as the frequency deviation caused by a Reflector Voltage deviation of 1.0 Volt.								
10.	The Reflector Voltage for Mode Optimum shall be plotted as a function of the angular position of the Tuning Shaft over the frequency range 9,000 to 10,000 Mc/s., at intervals corresponding to approximately 100 Mc/s. The tracking error is defined as the voltage deviation of this plotted curve from the straight line drawn through the two voltages corresponding to 9,000 and 10,000 Mc/s.								
11.	In order to avoid resetting errors there shall be no reversal of the direction of the rotation of the Tuning Shaft throughout the test.								
12.	The frequency of oscillation, with the Reflector Voltage adjusted for Mode Optimum, shall be plotted as a function of the angular position of the Tuning Shaft over the frequency range 9,000 to 10,000 Mc/s, at intervals corresponding to approximately 100 Mc/s. The limits apply to the minimum and maximum gradients of this plotted curve.								

NOTES (Contd.)

13. The number of turns of the Tuning Shaft, in a clockwise direction, to change the frequency from 9,000 to 10,000 Mc/s., with the Reflector Voltage adjusted to Mode Optimum, shall be divided into 1,000.
14. The Resetting Error is defined as the maximum difference between possible frequencies for the same angular position of the Tuning Shaft for a reversible frequency excursion of approximately 100 Mc/s.
15. The Reflector Voltage to be adjusted initially for Mode Optimum.
16. To be measured when the valve is working into a load of V.S.W.R. not greater than 1.5 to 1, moved through all phases. The power-reflector voltage characteristic and the frequency-reflector voltage characteristic must be continuous between the ± 10 Mc/s., points of the mode.
17. The valve to be clamped to the vibration mount by its flange and subjected to a sinusoidal vibrational acceleration, along its axis, over the vibrational frequency band and with the acceleration levels shown in Page 7, at a rate of change of frequency not exceeding 1 octave per minute. The limit applies to the peak to peak modulation of the R.F. Output.
18. The valve shall be mounted by its flange and subjected to a constant acceleration of 50g in a direction along the axis of the valve from the reflector to the base, for a time not less than $\frac{1}{2}$ minute and not greater than 2 minutes.
19. The body temperature measured at a point on the Resonator body diametrically opposite the waveguide output.
20. The valve shall be tested in accordance with Note 17 except that the valve shall be vibrated successively along three mutually perpendicular directions, one of which shall be along the axis of the valve. The rate of change of frequency shall not exceed 1 octave per 5 minutes.
21. The valve shall be mounted by its flange and subjected to a constant acceleration of 50g, applied successively in three mutually perpendicular directions, one of which shall be along the axis of the valve from the reflector to the base. The acceleration shall be applied for not less than $\frac{1}{2}$ minute and not greater than 2 minutes.
22. This test, which is to be a measurement of Starting Torque, is to be made:-
 - (a) With all supplies off and all parts of the valve stabilised in an ambient temperature of 10°C max.
 - (b) With all supplies on and the valve body temperature at 100°C. min.
23. Record readings - not to be acceptance tests at present.
24. The Reflector Voltage shall be adjusted to give maximum Power Output at 9,500 Mc/s approx. The Tuner shall be cycled over the range corresponding to 9,000 to 10,000 Mc/s. at a rate of not greater than 100 r.p.m.
25. The valve shall meet the following tests as specified in Group A:-
 - (1) Reflector Voltage Tracking Error
 - (2) Average Mechanical Tuning Gradient
 - (3) Incremental Mechanical Tuning Gradient
 - (4) Torque to Turn Tuning Shaft (1)
 - (5) Resetting Error
 - (6) Frequency Modulation Under Vibration (1)
 - (7) Frequency Deviation under Acceleration (1)
 - (8) Power Deviation under Acceleration (1)
26. Each cycle shall comprise the following schedule:-
 - (1) Vh = 9.0 Volts for 20 seconds.
 - (2) Vh = 6.3 Volts for 5 minutes.
 - (3) Vh = Zero for 5 minutes.
27. The Test End Point is defined as the number of cycles at which the Heater becomes inoperative.

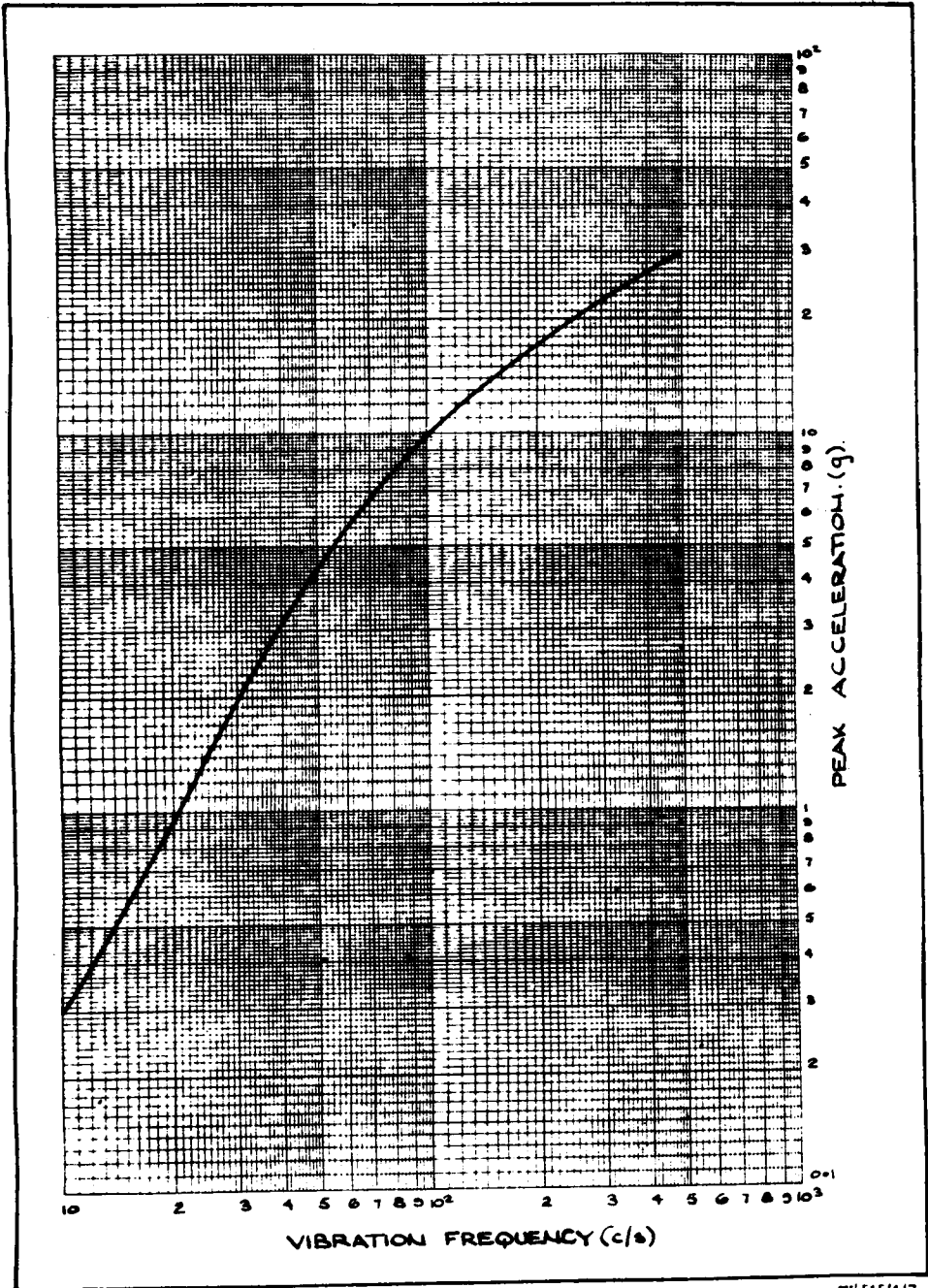

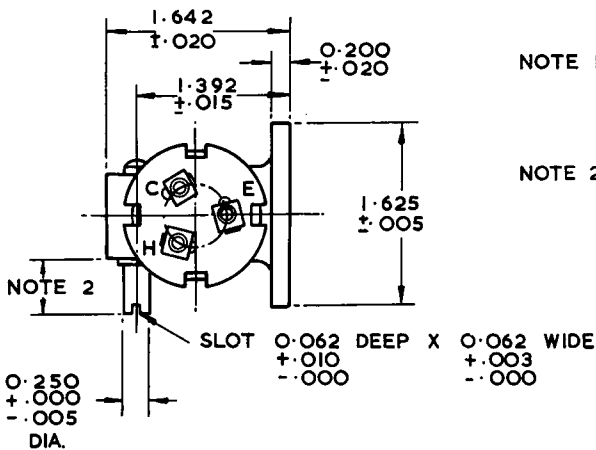
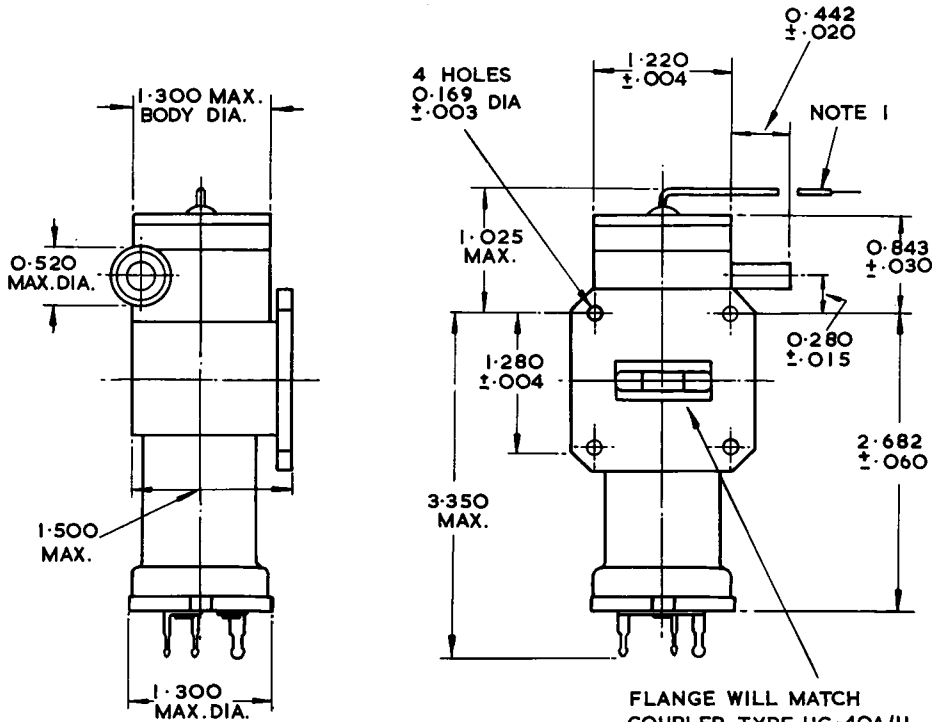

- NOTE 1. REFLECTOR CONNECTION. STRANDED FLYING LEAD 2.5 MIN. LENGTH 0.028 DIA. COPPER COATED WITH 1/8 DIA. NOMINAL, SILICON RUBBER.
- NOTE 2. USABLE LENGTH OF SHAFT 0.406 MIN.

PIN	ELEMENT
H	HEATER
C	HEATER & CATHODE
E	RESONATOR

ALL DIMENSIONS IN INCHES