



AC/ME

A.C. MAINS CATHODE RAY TUNING INDICATOR

RATING.

Heater Voltage	4.0
Heater Current (Amps.)	0.5
Maximum Anode Voltage	250
Maximum Target Voltage	250

OPERATING CONDITIONS.

H.T. Supply Voltage	250
Target Current (mA) (approx.)	1.5
*Anode Current (at $V_g=0$) (approx.)	0.24
*Grid Volts (0° shadow angle) (approx.)	22.0

* For anode load resistance of 1 megohm

DIMENSIONS.

Maximum overall length	107 mm.
Maximum diameter	38 mm.

GENERAL.

The AC/ME is an indirectly heated cathode ray tuning indicator, for use on A.C. mains. It is designed to indicate visually, by means of a fluorescent target, the effects of change of the applied voltage on the control grid. The cathode acts as a source of electrons which are attracted to a positively charged target coated with a fluorescent material. The electrons impinging on the coated target cause it to glow, and the extent of the fluorescent area is controlled by means of a ray control electrode placed between the cathode and the target. When the potential of the control electrode is increased from a low positive potential to a high positive potential, the area of shadow produced on the target is reduced. The electrode is connected internally to the anode of the triode, and in use a high resistance is placed in the triode anode circuit so that it operates as a resistance coupled D.C. amplifier. The shadow which starts with an angle of approximately 90° with zero bias, can be reduced to zero by applying sufficient bias to the control grid. The target should be connected directly to a positive supply of 250 volts, and the triode anode connected to the target through a load resistance of about 1 megohm. The cathode should be connected to the cathode of the detector valve. The valve is based in a standard 7-pin base, the connections to which are given overleaf.

APPLICATION.

The grid of the valve should always be controlled from the detector circuit, and not the A.V.C. diode circuit, so as to enable visual tuning to be obtained below the delay point. This also eliminates the possibility of two tuning positions giving a minimum value if either transformer has a double humped primary response. The tapping values controlling the ratio of D.C. volts applied to the control grid should be arranged to give a suitable deflection on a local station.

MAZDA

BASING.

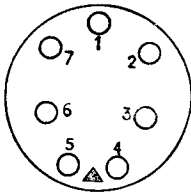

Viewed from the free end
of the base.

- Pin No. 1. —
 2. Control Grid.
 3. Target.
 4. Heater.
 5. Heater.
 6. Cathode.
 7. Anode.

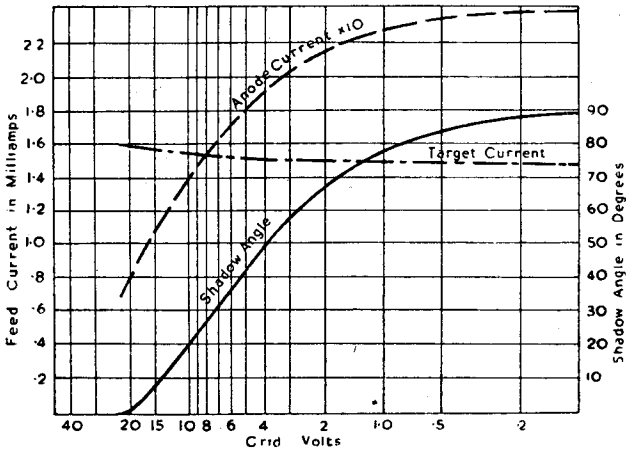

CIRCUIT DIAGRAM.

Values of components:

R_1 2 megohms.

R_2 2 megohms.

R_3 1 megohm.

These values are representative only and the value of R_2 may need alteration to suit individual circuit conditions.

IMPORTANT. A condenser of 0.1 mfd. should be connected between the grid and cathode of the AC/ME.

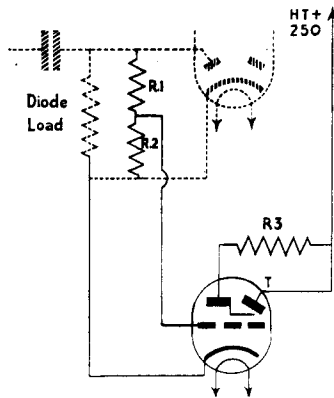

*Mazda Radio Valves are manufactured in Great Britain for
the British Thomson-Houston Co. Ltd., London and Rugby.*